

# GARAGES, ONE-STORY



City of  
**Maple Grove**

**BUILDING DEPARTMENT**

**763-494-6060**

[www.ci.maple-grove.mn.us](http://www.ci.maple-grove.mn.us)



This handout is intended only as a guide and is based in part on the 2007 Minnesota State Building Code, Maple Grove City ordinances, and good building practice. While every attempt has been made to insure the correctness of this handout, no guarantees are made to its accuracy or completeness. Responsibility for compliance with applicable codes and ordinances falls on the owner or contractor. For specific questions regarding code requirements, refer to the applicable codes or contact your local Building Department.

## PLANS

Building plans (two copies) must be submitted with an application to construct a garage or garage addition. Plans must be neatly drawn and **to scale** (at least 1/8" = 1 ft. min.). They may be on 8 1/2 X 11 paper. Plans must include a **site plan, floor plan, cross section and elevation**. Plans should show the proposed size of the garage; location and size of window and door openings; size of headers over all window and door openings; size, spacing, and direction of rafters or trusses; rafter/truss connection method; size and spacing of studs; the grade and species of lumber to be used; the type of roof and wall sheathing used; information on siding and roofing; and any other pertinent information.

## FOUNDATIONS

Detached garages may be constructed on a thickened-edge slab. Attached garages must be constructed on a foundation extending at least 42 inches below finished grade.

## WALL CONSTRUCTION

Walls may be framed with minimum No. 3 grade studs spaced 16 or 24 inches on center. Utility grade studs may be used when supporting only a roof, spaced not more than 16 inches on center, and limited to 8 feet in height. All other studs shall be limited to ten feet in height. If a single top plate is used, rafters or trusses must be centered over studs.

## WALL BRACING

All walls are required to be braced at each end of each wall by one of the following methods:

- Nominal 1X4 continuous diagonal braces let in to top and bottom plates and the intervening studs or approved metal straps installed in accordance with the manufacturer's specifications. Braces must be installed at an angle not to exceed 60 degrees or less than 45 degrees.
- 4X8 wood structural panel sheathing not less than 5/16 inch for 16-inch stud spacing and not less than 3/8 inch for 24-inch stud spacing. Sheathing must be attached with a minimum of 6d nails at 12 inches on center.

- 4X8 structural fiberboard sheathing not less than ½ inch thick applied vertically on studs spaced 16 inches on center. Sheathing must be attached with 1½ inch galvanized roofing nails, 6d common nails, or 16 ga 1½ inch staples spaced 3 inches on center around the perimeter and 6 inches on center on intermediate studs.

When garages are fully sheathed with wood structural panel sheathing, wall segments on either side of garage openings that support light frame roofs only with roof covering dead loads of 3 psf or less shall be permitted to have a 4:1 aspect ratio. For narrower wall segments, see page 6 of this handout.

## **ROOF TRUSSESS**

Wood trusses may be used as long as they are designed to meet state snow load requirements. Trusses must be connected to walls with approved connectors. Truss design drawings must be provided.

## **GARAGE DOORS**

Garage doors must meet minimum wind resistance standards and must come with a *label* indicating the door complies with ANSI/DASMA 108.

## **GARAGE DOOR OPENERS**

State law requires that all automatic garage door openers sold and installed be equipped with an automatic reversing device. This means that the door must have a means to reverse the closing function if something is detected in the path of the door.

## **ZONING REQUIREMENTS**

The combined total square footage of attached garages, detached garages, and accessory buildings cannot exceed **1,254 square feet**.

A maximum of two (2) detached accessory buildings are allowed per lot. If two (2) detached buildings are erected, one (1) must be no larger than **150 square feet**.

No garage or accessory building shall exceed **1,000 square feet** in area or a height of **15 feet**.

## **INSPECTIONS**

It is the responsibility of the permit applicant to call the Building Department to arrange for the inspections. 24-hour advance notice is required. Inspections typically required for the construction of a garage are:

- Footing and foundation inspections (attached garages only) after form work is in place but prior to pouring concrete.
- Slab Inspection – To be made after all formwork and reinforcing is in place but prior to the pouring of concrete.
- Framing Inspection – To be made after all framing and bracing is complete, rough electrical (if any) is approved, but prior to the application of siding or roofing.
- Final Inspection – To be made upon completion of the garage and grading is complete.

## HEADER SIZES FOR GARAGES 20, 24, AND 28 FT WIDE

	20 Ft WIDE		24 Ft WIDE		28 Ft WIDE	
Span	Header Size	# Jack Studs	Header Size	# Jack Studs	Header Size	# Jack Studs
Up to 3 ft	2-2X4	1	2-2X4	1	2-2X6	1
Up to 4 ft	2-2X6	1	2-2X6	1	2-2X6	1
Up to 6 ft	2-2X8	2	2-2X10	2	2-2X10	2
Up to 7 ft	2-2X10	2	2-2X12	2	2-2X12	2
Up to 8 ft	2-2X12	2	3-2X10	2	3-2X10	2
Up to 9 ft	3-2X10	2	3-2X12	2	3-2X12	2
Up to 10 ft	3-2X12	2	4-2X12	2	4-2X12	2
Up to 12 ft	4-2X12	2	*EWPR		*EWPR	
Over 12 ft	*EWPR		*EWPR		*EWPR	

\*Engineered wood product required

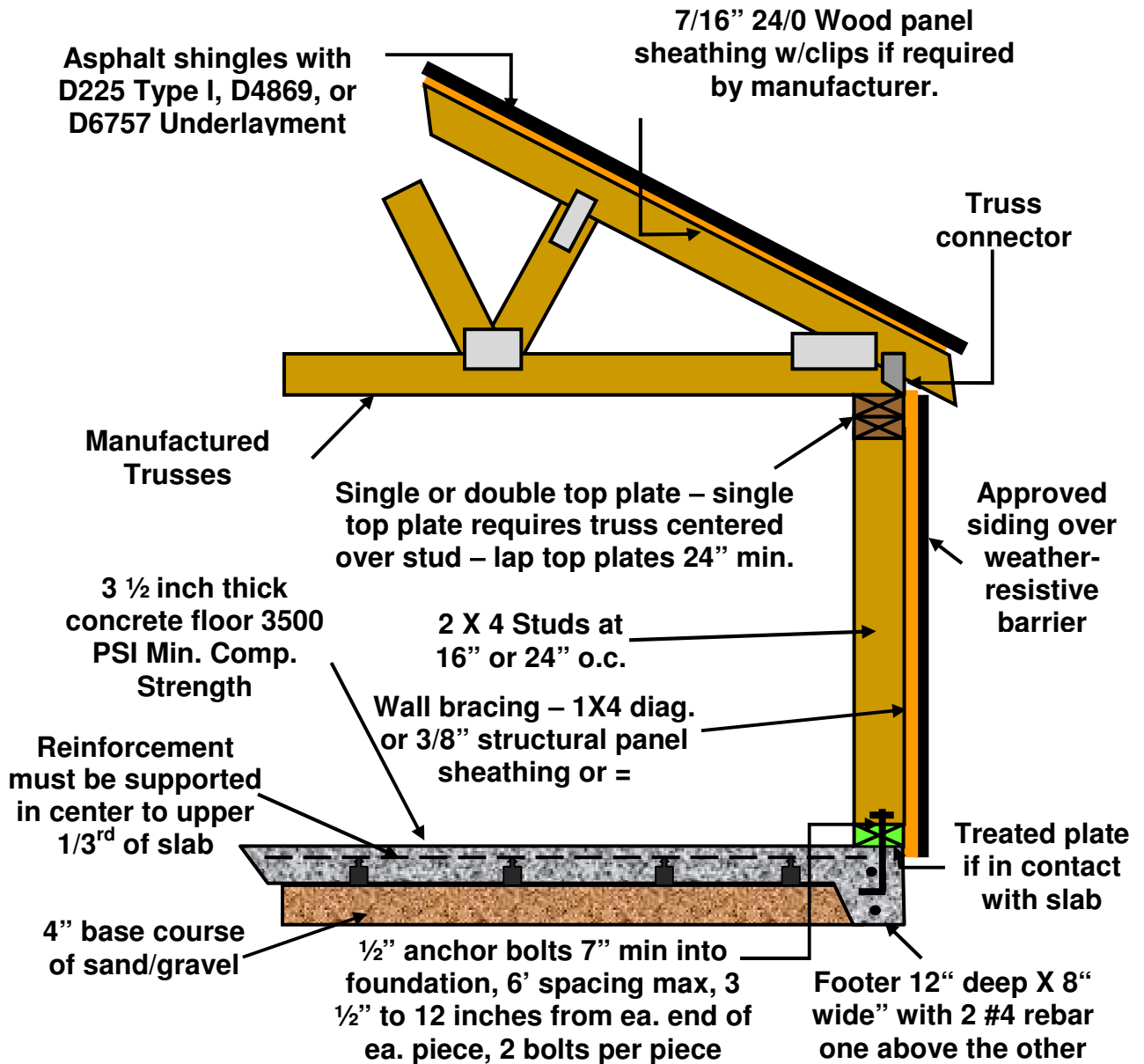

RAFTER SPANS FOR #2 HEM FIR AND SPF					
		2 x 4	2 x 6	2 x 8	2 x 10
12" o.c.	Hem Fir	7'5"	11'1"	14'0"	17'2"
	SPF	7'8"	11'3"	14'3"	17'5"
16" o.c.	Hem Fir	6'7"	9'7"	12'2"	14'10"
	SPF	6'8"	9'9"	12'4"	15'1"
24" o.c.	Hem Fir	5'4"	7'10"	9'11"	12'1"
	SPF	5'5"	7'11"	10'1"	12'4"

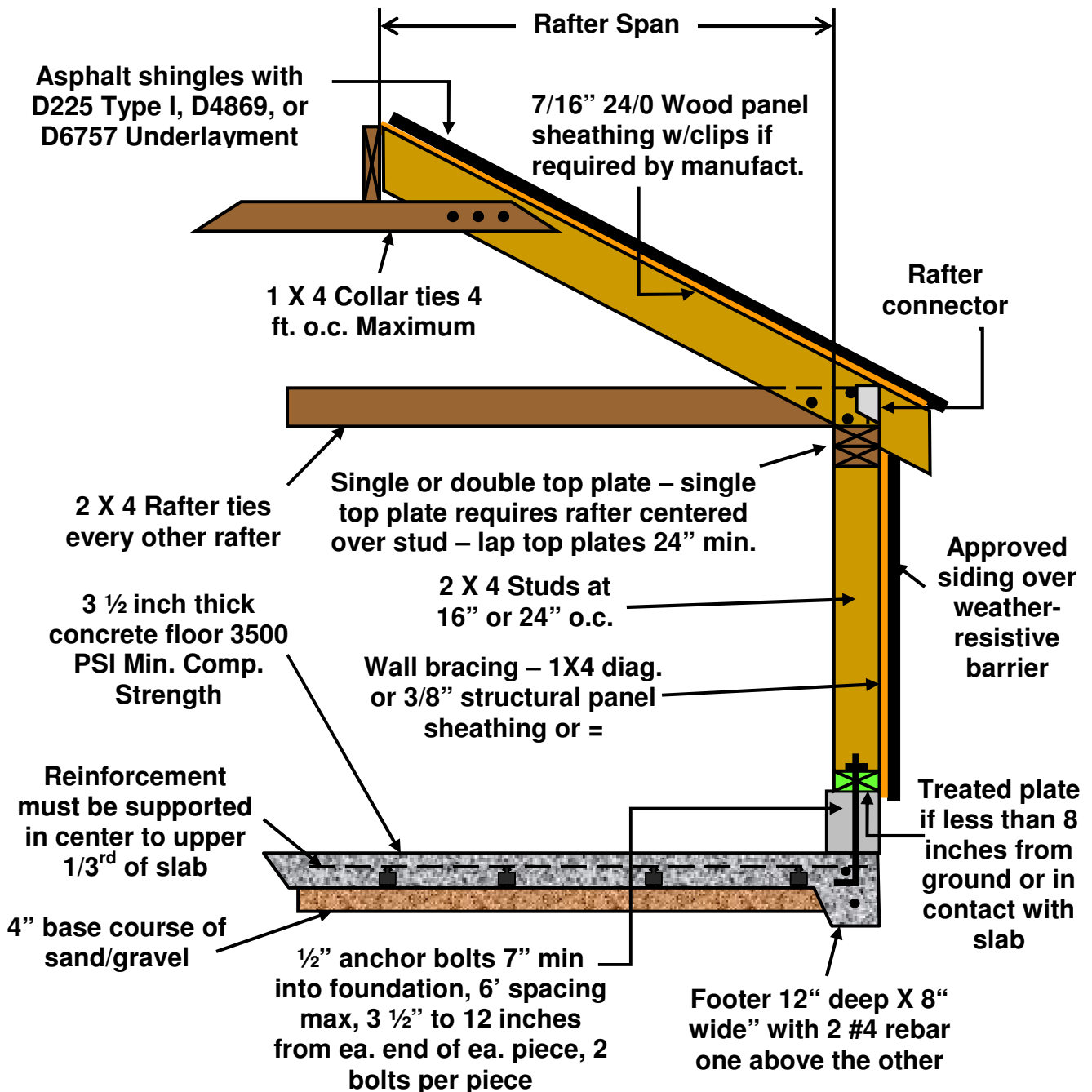

## FOUNDATION DETAIL FOR ATTACHED GARAGE

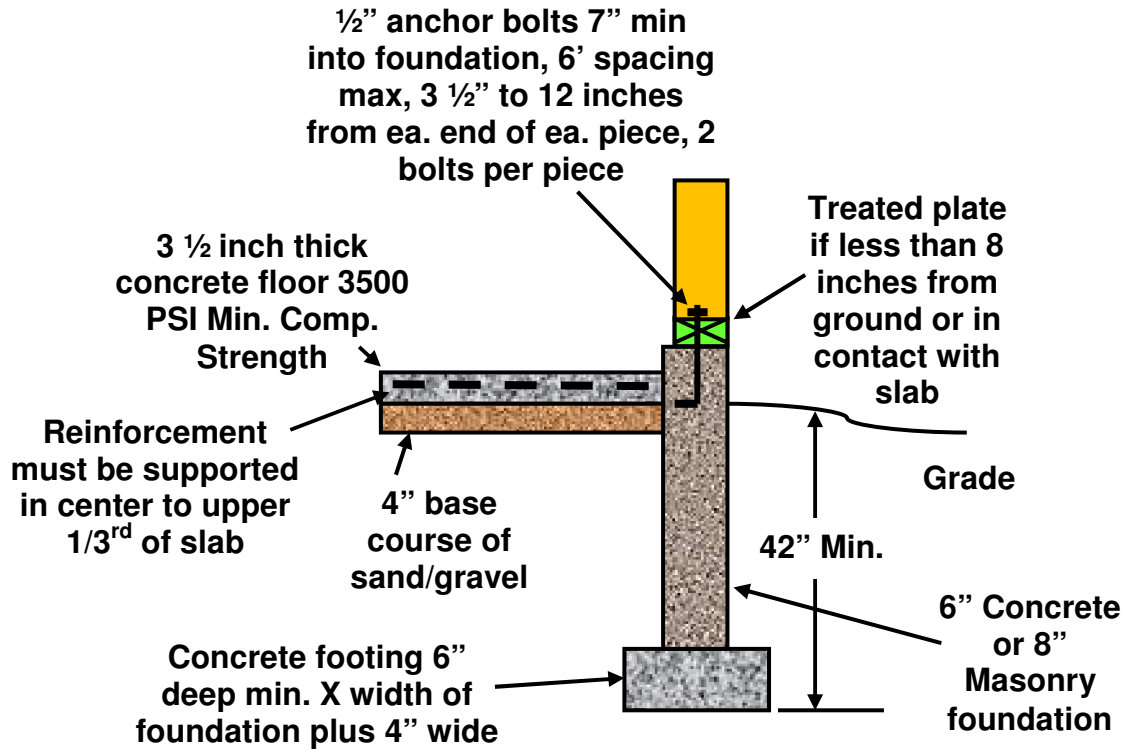

## SEPARATION WALL DETAIL FOR ATTACHED GARAGE

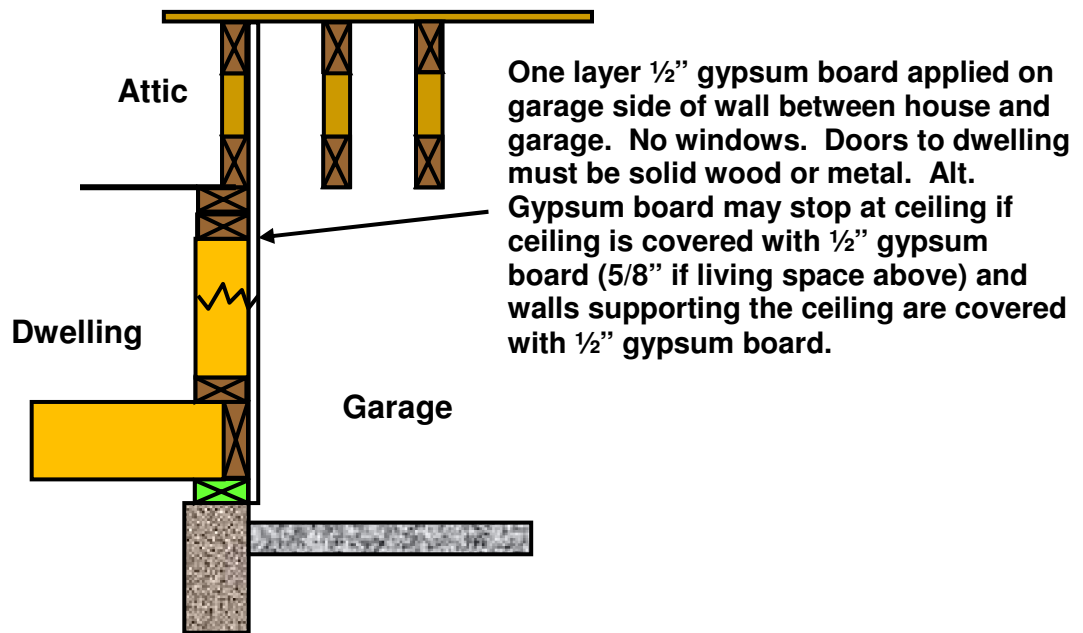

# WALL BRACING

FRONT ELEVATION

SIDE OR REAR ELEVATION

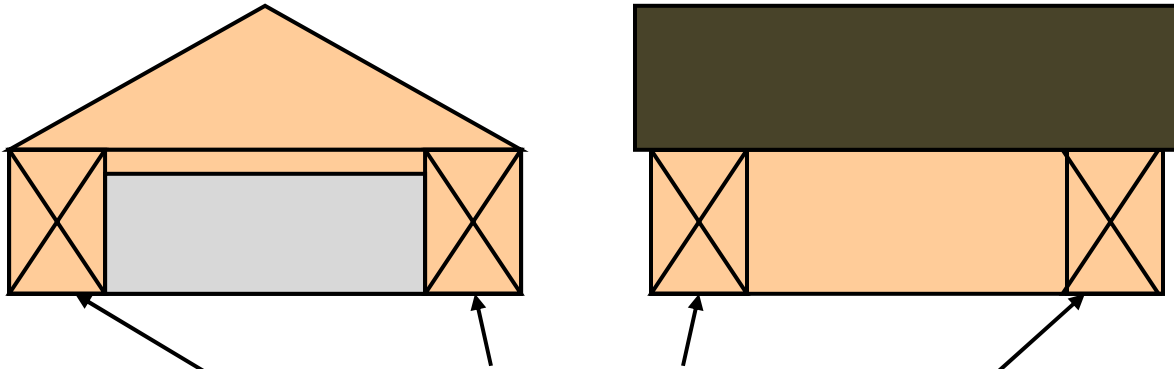

4 Ft X 8 Ft 5/16" (16" o.c.) or 3/8" (24" o.c.) wood structural panels or 1/2" structural fiberboard sheathing or let-in bracing

## WALL BRACING FOR NARROW WALLS

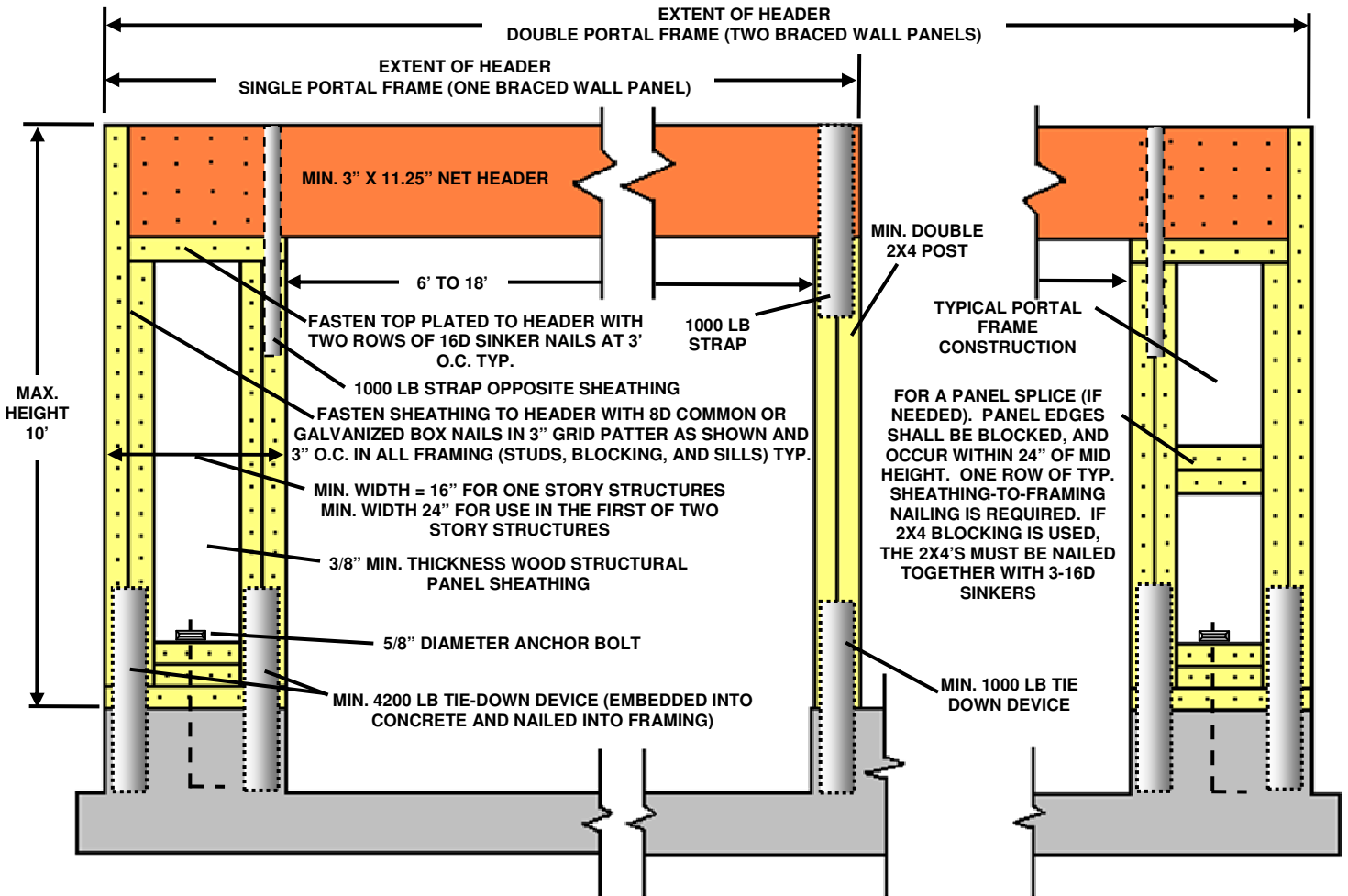

ALTERNATE BRACED WALL PANEL ADJACENT TO A DOOR OR WINDOW OPENING